

> HGA HT

AIR - WATER
HEAT PUMPS
FOR OUTDOOR INSTALLATION

Available range

Unit type

IP Reversible heat pump
(reversible on the refrigerant side)

Versions (heat recovery)

VB Base version
VD Desuperheater version

Acoustic setting up

AB Base setting up
AS Low noise setting up

Unit description

This series of **air-water** heat pumps satisfies the heating, cooling and domestic hot water production requirements of autonomous or centralized residential plants of medium and large size.

All the units are suitable for outdoor installation. The possibility to produce water at high temperatures makes these units particularly suitable to be applied to **radiators** plants as well as to **fan coil** plants and **radiant** floor plants.

The control system allows to manage not only the refrigerant circuit but the whole plant with the possibility to choose different solutions both for the heating and cooling plant and for the domestic hot water management. The possibility of solar panels or other heating sources integration is also available.

The **heating** function optimizes the flow water temperature according both to the ambient temperature and to the outdoor temperature through climatic curves adaptable to the building features. It's possible to manage a storage tank and two independent circuits (a direct one and a mixed one).

The **domestic hot water** management allows to control the three way valve, the storage tank and the anti-legionella cycles (if necessary).

The **cooling** function can be realized through "active cooling" (refrigerant circuit inversion). When the unit is used in radiant floor plants, to avoid condensate generation, a room humidity sensor can be installed. During cooling mode operation a part of the heating power in excess can be recovered for the domestic hot water production (VD version).

The **internal programmer clock** allows

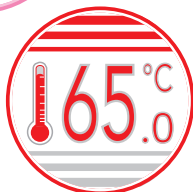

to define different daily switching programs for heating, cooling and domestic hot water production.

The refrigerant circuit, contained in a box repaired from the air flow to simplify the maintenance operations, is equipped with two scroll compressors mounted on damper supports, brazed plate heat exchangers, electronic expansion valve, reverse cycle valve, axial fans, finned coil realized with copper pipes and aluminium fins. The circuit is protected by high and low pressure switches and flow switches on the plate heat exchanger.

The compressors are arranged in tandem on a single refrigerant circuit and allow the capacity modulation according to the plant requests in order to guarantee a high seasonal efficiency.

Both the compressors are equipped with vapour and liquid injection and are placed on an economized refrigerant circuit with plate heat exchanger and electronic expansion valve dedicated to the injection.

The plate heat exchanger and all the hydraulic pipes are thermally insulated in order to avoid condensate generation and reduce thermal losses.

The axial fans, equipped with electronic control of the rotational speed, guarantee high efficiencies in all the operating conditions and the possibility to reduce the noise level during the night.

All the units are provided with a phase sequence and correct sequence controller device and with an outdoor temperature sensor in order to realize the climatic control.

All the units are accurately built and indi-

vidually tested in the factory. Only electric and hydraulic connections are required for installation.

Options

Plant side flow rate management

- not present
- standard pump
- high head pump
- modulating pump

Domestic hot water production

- not present
- 3 way valve

Soft starter

- not present
- standard

Accessories

Rubber vibration dampers

Coil protection grilles

Remote thermostat (wired or wireless)

Remote control (wired or wireless)

Wireless transmitter

Wireless repeater

Condensate sensor

Room hygrosat

Room humidity sensor

CONTROL SYSTEM

The microprocessor controller is able to manage not only the unit itself but also all that components of the plant which allow to realize a complete system.

The main **functions** of the control system are :

- room temperature control according to the outdoor temperature (climatic control)
- domestic hot water production (management of 3 way valve, storage tank, anti legionella cycles...)
- management of a heating and/or cooling mixed circuit (pump and 3 way mixing valve)
- management of a heating direct circuit (only pump)
- management of a storage tank for heating and/or cooling
- management of electrical heaters for heating and domestic hot water (3 steps logic)
- solar panels integration
- room humidity control for cooling with radiant systems
- internal programmer clock (for heating, cooling and domestic hot water)
- digital input for electrical energy low tariff
- alarm memory management and diagnostic
- compressor and pump operating hour counter
- possibility to manage more units in cascade (maximum 16)

Besides the standard user interface to be placed indoor, wired or wireless remote thermostats are available which allow to control all the operating parameters of the unit and to acquire the temperature in the different zones in order to realize a more precise and comfortable control.

The unit controller is able to manage a lot of different plant solutions enabling automatically the necessary control algorithms according to the components which have been connected.

The management of such components is possible through additional expansion modules which communicate with the unit by means of an internal bus and provide all the inputs and outputs required to fulfil a complete system.

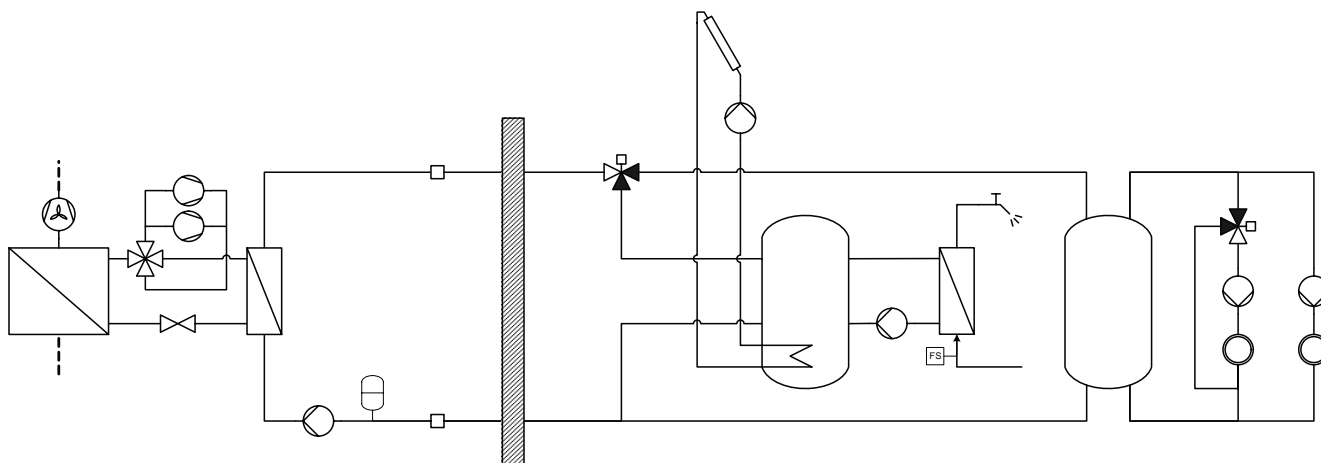
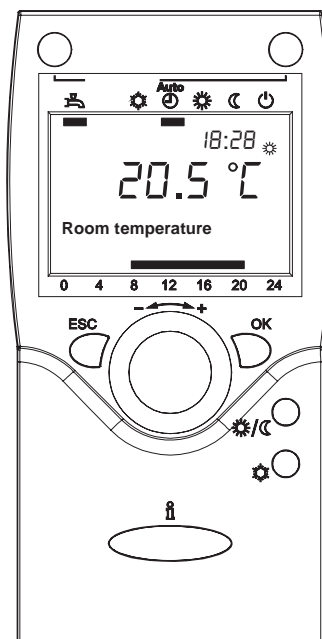

The controller is able to manage up to **two zones in heating** (one by means of a mixed circuit and the other by means of a direct circuit) and **one zone in cooling** (by means of a mixed circuit).

It's possible to realize more complex plants connecting to the heat pump controller further expansion modules in order to extend without limits the number of zones to be managed.

For each zone the following parameters can be set :

- set point
- daily or weekly operating time table
- climatic control curve
- room control sensor : it can be in common with the other zones or independent (in that case it's necessary to install an additional room thermostat)

OPERATING LIMITS	Unit type	Cooling		Heating		°C
		min	max	min	max	
Outdoor air inlet temperature	IP	5	50	-22	42	°C
Water outlet temperature	IP	6	25	30	65 *	°C

* The maximum water outlet temperature can be increased up to 70°C keeping a ΔT between inlet and outlet equal to 10°C.

NOMINAL performances - Radiant plants

IP	Acoustic setting up : AB and AS	60.2	70.2	80.2	90.2	100.2	
A7W35	Heating capacity	57,5	67,8	75,7	85,4	99,5	kW
	Power input	12,2	14,4	16,1	18,1	21,1	kW
	COP	4,71	4,71	4,70	4,72	4,72	-
	Water flow rate plant side	9923	11689	13058	14737	17179	l/h
	Pressure drops plant side	22	24	24	22	21	kPa
A2W35	Heating capacity	48,5	57,3	63,9	72,1	84,0	kW
	Power input	12,2	14,4	16,1	18,1	21,1	kW
	COP	3,98	3,98	3,97	3,98	3,98	-
	Water flow rate plant side	8382	9888	11031	12451	14512	l/h
	Pressure drops plant side	16	18	18	16	16	kPa
A35W18	Cooling capacity	58,7	69,1	77,3	87,1	102	kW
	Power input	15,3	18,1	20,2	22,7	26,6	kW
	EER	3,84	3,82	3,83	3,84	3,83	-
	Water flow rate plant side	10156	11966	13380	15070	17587	l/h
	Pressure drops plant side	23	25	25	22	22	kPa

NOMINAL performances - Standard plants

IP	Acoustic setting up : AB and AS	60.2	70.2	80.2	90.2	100.2	
A7W45	Heating capacity	58,2	68,6	76,6	86,4	101	kW
	Power input	15,6	18,4	20,5	23,1	27,0	kW
	COP	3,73	3,73	3,74	3,74	3,74	-
	Water flow rate plant side	10080	11870	13260	14963	17449	l/h
	Pressure drops plant side	22	24	25	22	22	kPa
A2W45	Heating capacity	49,3	58,2	64,9	73,3	85,4	kW
	Power input	15,5	18,3	20,5	23,1	27,0	kW
	COP	3,18	3,18	3,17	3,17	3,16	-
	Water flow rate plant side	8551	10080	11244	12704	14807	l/h
	Pressure drops plant side	17	18	18	16	16	kPa
A35W7	Cooling capacity	44,6	52,6	58,7	66,2	77,2	kW
	Power input	14,1	16,6	18,6	20,9	24,5	kW
	EER	3,16	3,17	3,16	3,17	3,15	-
	Water flow rate plant side	7671	9044	10091	11378	13283	l/h
	Pressure drops plant side	14	15	15	14	14	kPa

NOMINAL performances - HIGH temperature and VERY HIGH temperature plants

IP	Acoustic setting up : AB and AS	60.2	70.2	80.2	90.2	100.2	
A7W65	Heating capacity	60,5	71,2	79,5	89,8	105	kW
	Power input	23,8	27,9	31,3	35,3	41,3	kW
	COP	2,54	2,55	2,54	2,54	2,54	-
	Water flow rate plant side	5293	6229	6955	7856	9160	l/h
	Pressure drops plant side	7	8	8	7	7	kPa
A2W65	Heating capacity	51,8	61,0	68,2	77,0	89,7	kW
	Power input	23,8	28,0	31,4	35,3	41,3	kW
	COP	2,18	2,18	2,17	2,18	2,17	-
	Water flow rate plant side	4532	5337	5967	6736	7847	l/h
	Pressure drops plant side	5	6	6	5	5	kPa
A7W55	Heating capacity	59,2	69,7	77,8	87,8	102	kW
	Power input	19,1	22,5	25,1	28,3	33,1	kW
	COP	3,10	3,10	3,10	3,10	3,08	-
	Water flow rate plant side	6440	7584	8466	9556	11147	l/h
	Pressure drops plant side	10	11	11	10	10	kPa
A2W55	Heating capacity	50,3	59,3	66,3	74,9	87,3	kW
	Power input	19,1	22,4	25,2	28,4	33,2	kW
	COP	2,63	2,65	2,63	2,64	2,63	-
	Water flow rate plant side	5481	6462	7213	8150	9502	l/h
	Pressure drops plant side	7	8	8	7	7	kPa

Data declared according to **EN 14511**. The values are referred to units without options and accessories.

A7W65 = source : air in 7°C d.b. 6°C w.b. / plant : water in 55°C out 65°C
 A7W55 = source : air in 7°C d.b. 6°C w.b. / plant : water in 47°C out 55°C
 A7W45 = source : air in 7°C d.b. 6°C w.b. / plant : water in 40°C out 45°C
 A7W35 = source : air in 7°C d.b. 6°C w.b. / plant : water in 30°C out 35°C
 A35W7 = source : air in 35°C d.b. / plant : water in 12°C out 7°C
 A35W18 = source : air in 35°C d.b. / plant : water in 23°C out 18°C

A2W65 = source : air in 2°C d.b. 1°C w.b. / plant : water in 55°C out 65°C
 A2W55 = source : air in 2°C d.b. 1°C w.b. / plant : water in 47°C out 55°C
 A2W45 = source : air in 2°C d.b. 1°C w.b. / plant : water in 40°C out 45°C
 A2W35 = source : air in 2°C d.b. 1°C w.b. / plant : water in 30°C out 35°C

TECHNICAL DATA	60.2	70.2	80.2	90.2	100.2	
Power supply	400 - 3 - 50					V-ph-Hz
Compressor type	scroll with vapour injection (EVI)					-
N° compressors / N° refrigerant circuits	2 / 1					n°
Plant side heat exchanger type	stainless steel brazed plates					-
Source side heat exchanger type	finned coil					-
Fans type	axial					-
N° fans	2	3		4		n°
Hydraulic fittings	2" M					-
Hydraulic fittings heat recovery (VD)	1" 1/4 M					-

ACOUSTIC PERFORMANCES

Base acoustic setting up (AB)	60.2	70.2	80.2	90.2	100.2	
Sound power level	79	80	80	81	81	dB(A)
Sound pressure level at 1 metre	61	62	62	62	62	dB(A)
Sound pressure level at 5 metres	52	53	53	54	54	dB(A)
Sound pressure level at 10 metres	47	48	48	49	49	dB(A)
Low noise acoustic setting up (AS)	60.2	70.2	80.2	90.2	100.2	
Sound power level	76	77	77	78	78	dB(A)
Sound pressure level at 1 metre	58	59	59	59	59	dB(A)
Sound pressure level at 5 metres	49	50	50	51	51	dB(A)
Sound pressure level at 10 metres	44	45	45	46	46	dB(A)

The acoustic performances are referred to units operating in cooling mode at nominal conditions A7W35.

Unit placed in free field on reflecting surface (directional factor equal to 2).

The sound power level is measured according to ISO 3744 standard.

The sound pressure level is calculated according to ISO 3744 and is referred to a distance of 1/5/10 metres from the external surface of the unit.

DIMENSIONS AND MINIMUM OPERATING AREA

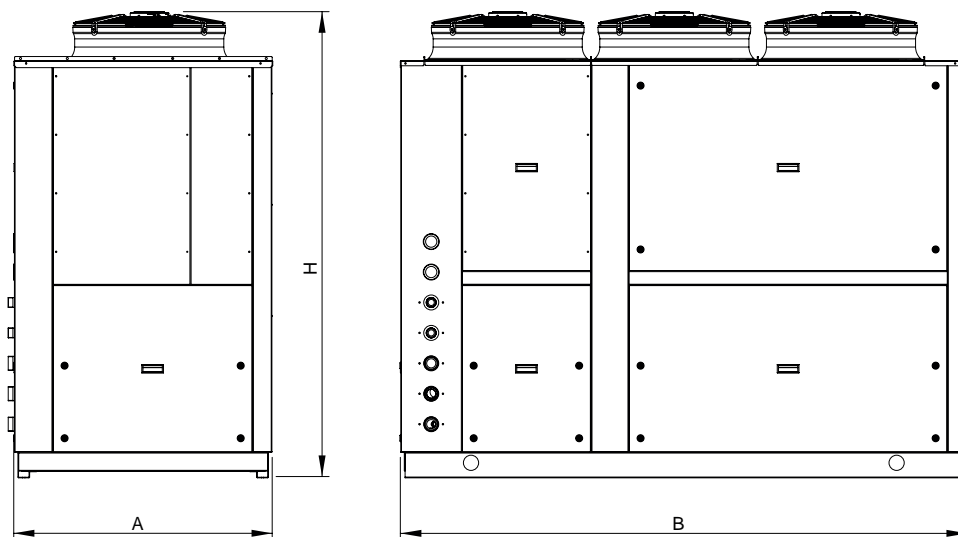

Respect the free area around the unit as shown in figure in order to guarantee a good accessibility and facilitate maintenance and control operations.

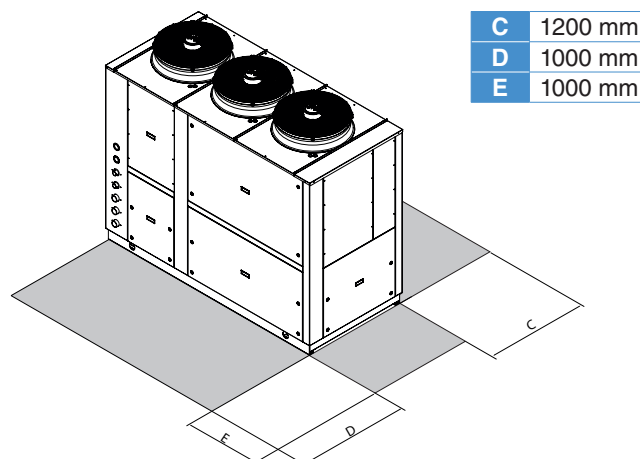

	60.2	70.2 - 80.2	90.2 - 100.2	
A	1130	1130	1130	mm
B	1710	2430	3130	mm
H	1980	1980	1980	mm