

KAIROS THERMO GR



Natural circulation indirect solar system for the production of domestic hot water:

- High performance TINOX collector surface (95% absorption)
- Easy and fast installation
- Reduced heat losses thanks to high heat insulation
- Solar Keymark certification
- Manufactured in accordance with European specification EN 12975 and EN 12976
- Antibacterial design for heating drinking water
- Consistent and immediate hot water supply
- Functional design
- Long life system

TECHNICAL DATA

		GR 200/1 TR	GR 300/2 TR
Technology		Closed circuit	Closed circuit
Number of collectors		1	2
Total height	m	1,3	1,3
Electric power	kW	2	2
Voltage	V	230	230
Angle of inclination	°	25	25
Domestic hot water storage tank capacity	l	190	276

- These tanks are designed for closed circuit and manufactured according to the European standard EN12976.
- They feature anticorrosive protection by the use of enamel according to DIN 4753-3 with anodic protection according to EN 12438





COLLECTOR

Groos area	m ²	2
Solar collector net absorber area	m ²	1,82
Efficiency	%	75
Absorber material		Aluminium
Absorber coating		Selective TINOX
Absorber tubing material		Copper
Solar collector frame		Aluminium
Insulation		Glass wool insulation
Thickness back side	mm	30
Welding type		Laser
Absorptivity	%	95
Emissivity	%	5
Glass material tempered		Low iron prismatic glass

TANK MODULE

DHW circuit max. pressure	bar	10
Tank material		Glass enamel steel (DIN 4753-3)
Insulation		Hard polyurethane foam
Insulation material thickness	mm	50
Maximum working temperature of the main tank	°C	95
External cover*		Pre-painted galvanized steel sheet

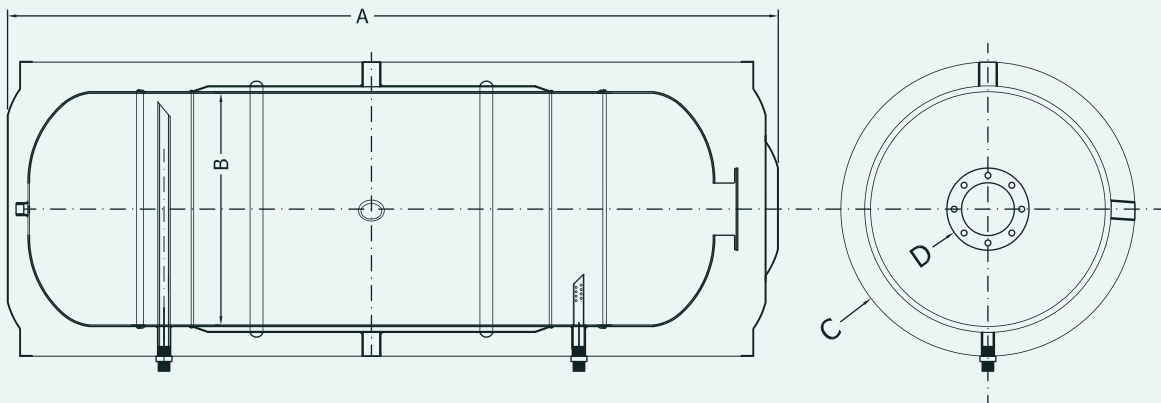

MODEL	200/1	300/2
Effective capacity (lt)	196	290
A - Tank's length (mm)	1250	1800
B - Main tank's diameter (mm)	Ø480	Ø480
C - External Diameter (mm)	Ø580	Ø580
Jacket's Surface (m ²)	0,81	1,55
Jacket's Capacity (lt)	12	24
D - Flange Diameter (mm)	Ø140	Ø140