



Domestic hot water thermal store ELX - AISI 316L stainless steel

ELV - Glass lined steel

Buffer vessel for the storage of domestic hot water (DHW) produced by external sources (boilers, PHE). The cylinder is available in two versions:
- AISI 316L stainless steel (Mod. ELX)

- Glass lined steel (Mod. ELV)
The inspection hatch can be also used to equip the cylinder with high power immersion heaters.

APPLICATION

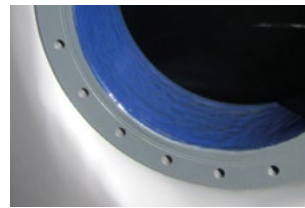
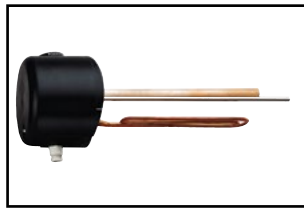

TECHNICAL FEATURES

DHW cylinder

General features

	ELX	ELV
Material	AISI 316L Stainless steel (1.4404)	Glass lined S 235 Jr Carbon steel
Internal protective treatment	Pickling and passivation	Enamelling according to DIN 4753.3
External protective treatment	Pickling and passivation	Anti rust protection + epoxy painting
Rating (P max. / T max.)	6 bar / 95°C	8 bar / 95°C
Cathodic protection	Magnesium anode	Magnesium anode
Capacity	200 - 1000 L	200 - 1000 L
Warranty	5 years	
Insulation	- Soft insulation with polyester + PVC: Fire retardant class B2 (DIN 4102) - Rigid polyurethane foam + PVC: Fire retardant class B3 (DIN 4102)	
In compliance with	- Pressure Equipment Directive (PED) 2014/68/UE Art. 4 Para 3 - Italian MOH specifications (products suitable to contain potable water) - Energy related Products (Erp) Directive 2009/125/CE	

ACCESSORIES
(page 218)



Impressed current electronic anode



Electronic control unit



Thermostat



Thermometer

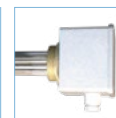

1 1/2 electric immersion heater

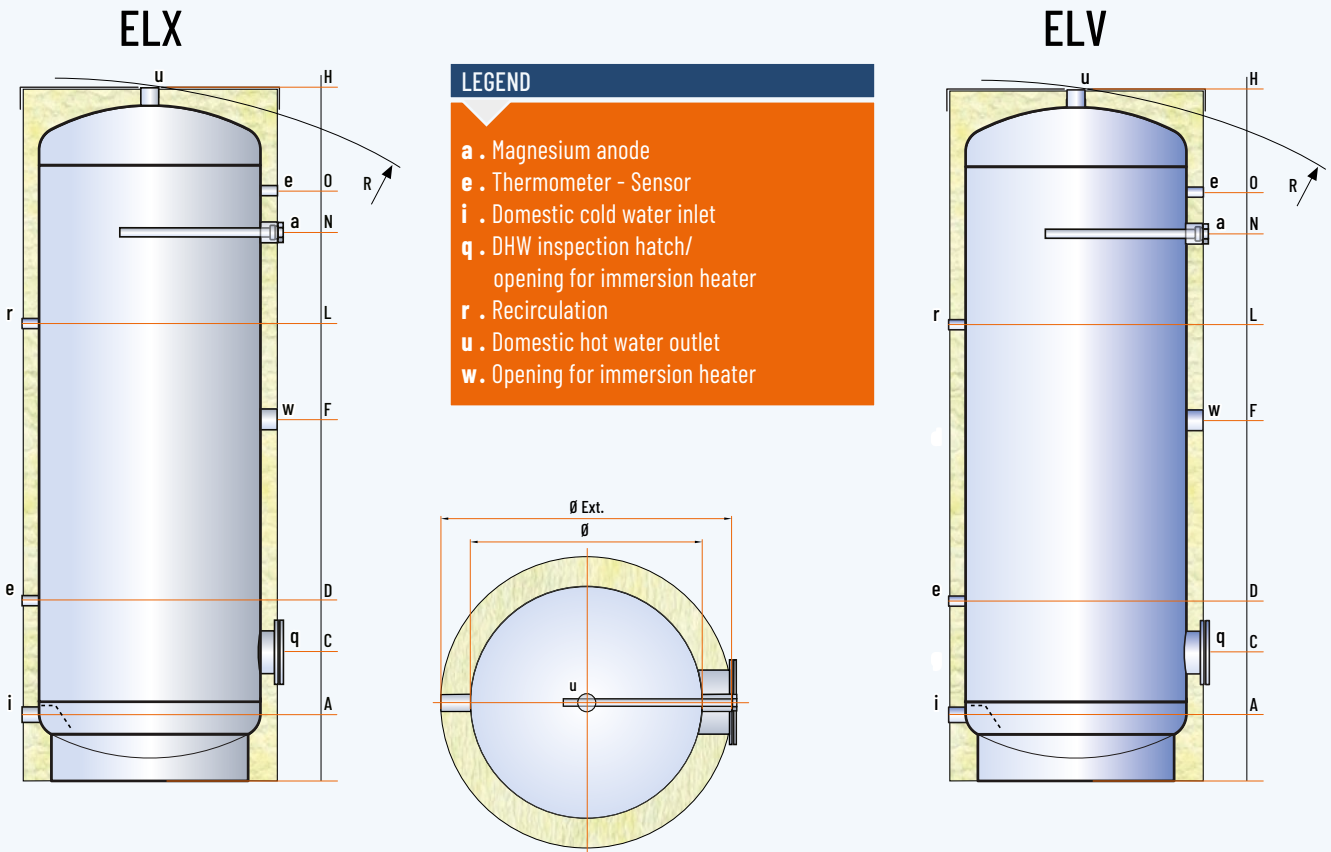

MODEL	DIMENSIONS (mm)		Ø EXT ** (Hard/Soft ins.)	R *	WEIGHT (kg)
	Ø	H			
ELX 00200 R	450	1305	550	1430	48
ELX 00300 R	500	1595	600	1720	59
ELX 00400 R	650	1395	750	1600	68
ELX 00500 R	650	1645	750	1820	76
ELX 00800_	790	1750	990/1050	1745	111
ELX 01000_	790	2100	990/1050	2095	129
ELV 00200 R	450	1320	550	1430	55
ELV 00300 R	500	1610	600	1730	68
ELV 00400 R	650	1410	750	1610	80
ELV 00500 R	650	1660	750	1835	90
ELV 00800_	790	1750	990/1050	1745	146
ELV 01000_	790	2100	990/1050	2095	171

* For capacities from 200 to 500 litres, the tilt height refers to the insulated cylinder

** The insulation is removable except for models from 200 to 500 litres

MODEL	HEIGHTS (mm)							CONNECTIONS (GAS)						
	A	C	D	F	L	N	O	a	e	i	u	r	w	q
ELX 00200 R	110	260	340	690	840	980	1090	1"¼	½"	1"	1"	½"	1"½	120/180
ELX 00300 R	120	300	405	845	1050	1250	1365	1"¼	½"	1"	1"	½"	1"½	120/180
ELX 00400 R	145	310	375	745	900	1030	1140	1"¼	½"	1"	1"	½"	1"½	120/180
ELX 00500 R	145	310	395	895	1095	1280	1390	1"¼	½"	1"	1"	½"	1"½	120/180
ELX 00800_	170	345	425	940	1200	1250	1425	1"¼	½"	1"½	1"½	1"	1"½	120/180
ELX 01000_	170	345	430	1090	1400	1450	1770	1"¼	½"	1"½	1"½	1"	1"½	120/180
ELV 00200 R	110	260	340	690	840	980	1090	1"¼	½"	1"	1"¼	½"	1"½	120/180
ELV 00300 R	120	300	405	845	1050	1250	1365	1"¼	½"	1"	1"¼	½"	1"½	120/180
ELV 00400 R	145	310	375	745	900	1030	1140	1"¼	½"	1"	1"¼	½"	1"½	120/180
ELV 00500 R	145	310	395	895	1095	1280	1390	1"¼	½"	1"	1"¼	½"	1"½	120/180
ELV 00800_	150	345	425	940	1200	1250	1425	1"¼	½"	1"½	1"¼	1"	1"½	120/180
ELV 01000_	150	345	430	1090	1400	1450	1770	1"¼	½"	1"½	1"¼	1"	1"½	120/180

Disclaimer: this layout is purely indicative. It does not replace consultant's design

LEGEND

- 1 . Domestic water expansion vessel
- 2 . Domestic water drain
- 3 . Domestic water safety valve (6 bar)
- 4 . Strainer
- 5 . Pressure reducing valve
- 6 . DWH Recirculation pump
- 7 . DWH 3-way valve

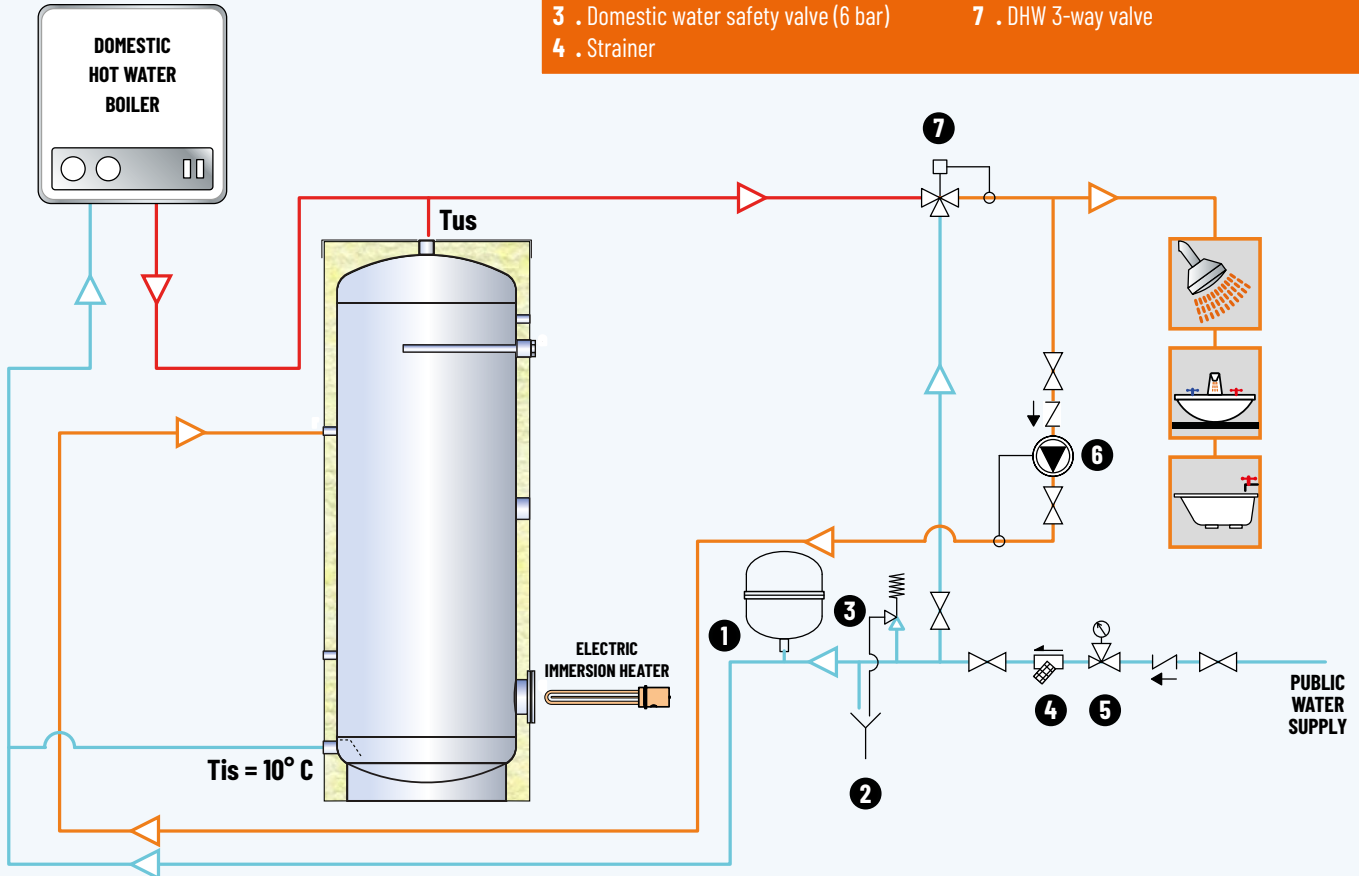

DHW THERMAL STORE