

mod. VHM 2.1-2.7

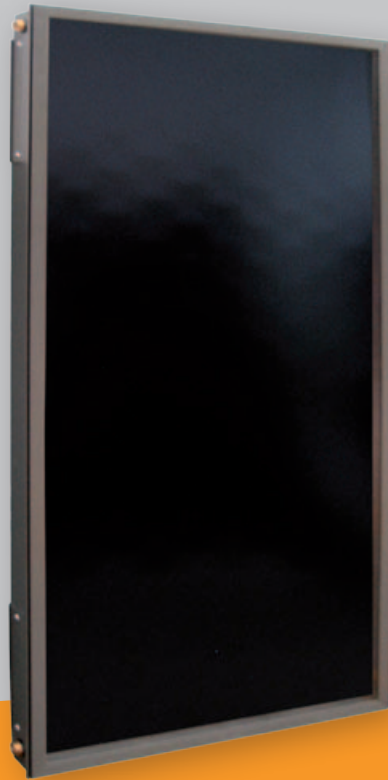

Ecotop VHM

High efficiency glazed flat-plate solar collectors

ferroli

> **QUALITY** CARE TO DETAILS

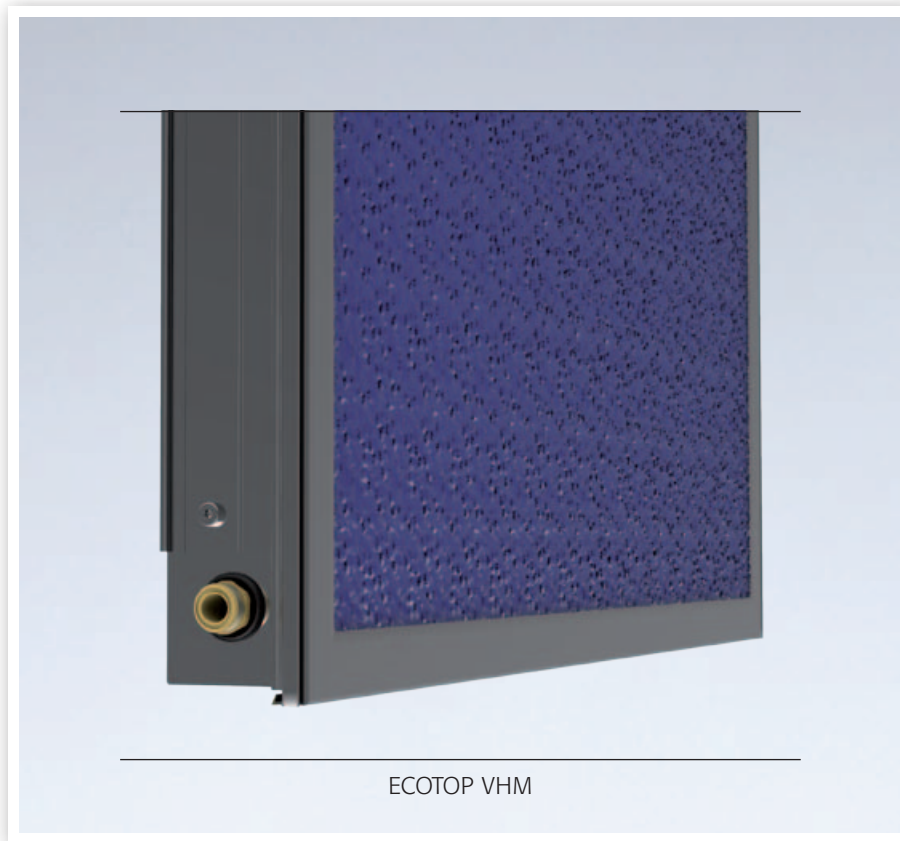

The prestigious voluntary **“Keymark”** certification achieved for the entire range of ECOTOP VHM flat-plate solar collectors demonstrates the passion and care that Ferroli has dedicated to its flat-plate solar collectors.

The use of environmentally-friendly and recyclable materials is the basis for the design of the Ferroli solar collectors.

The aluminium tray casing guarantees solidity, lightness and is easily recyclable.

The special glass ensures high transparency to sunlight and helps retain the infrared radiation re-emitted by the heat absorber inside the collector, maximising collector efficiency.

The highly selective absorber, can withstand extreme conditions of heat stress, humidity and the elements for many years.

The parallel distribution of the vertical tubes in the collector guarantees high efficiency and a more optimised operating field of the collector, even when used in multiple configurations.

This ensures more uniform temperature distribution in the collectors and prevents thermal stress on the welding inside the tubing, guaranteeing total collector reliability.

The precision laser welding of the inner tubing together with the continuous shape and high quality of the absorber guarantee the best quality results.

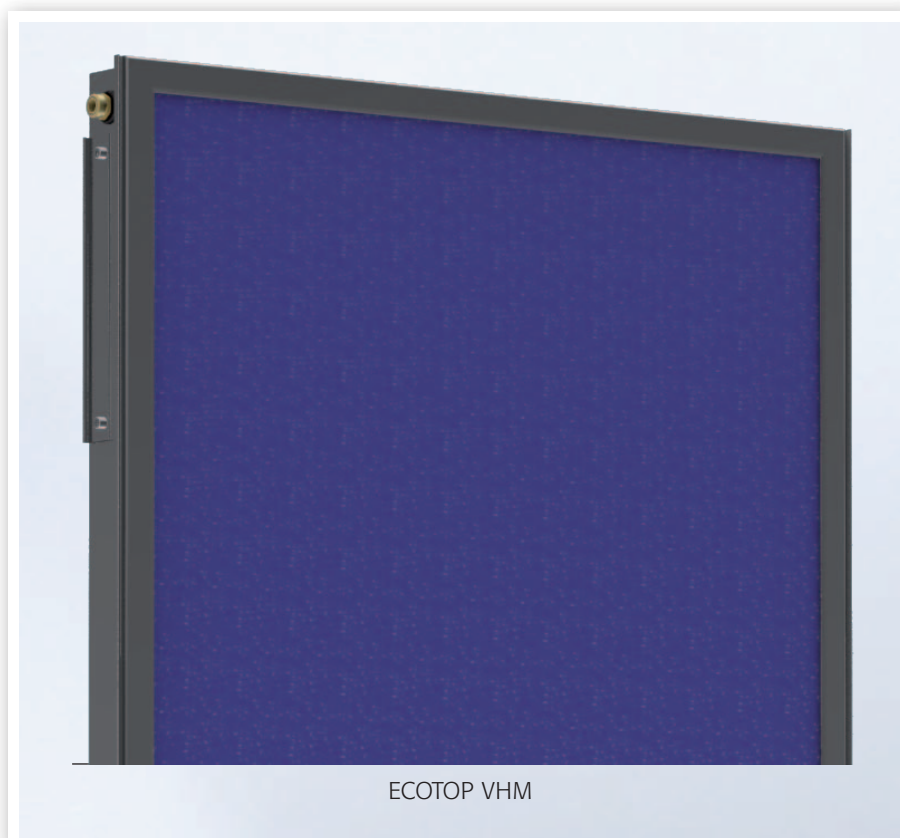

> **QUALITY** CARE TO DETAILS

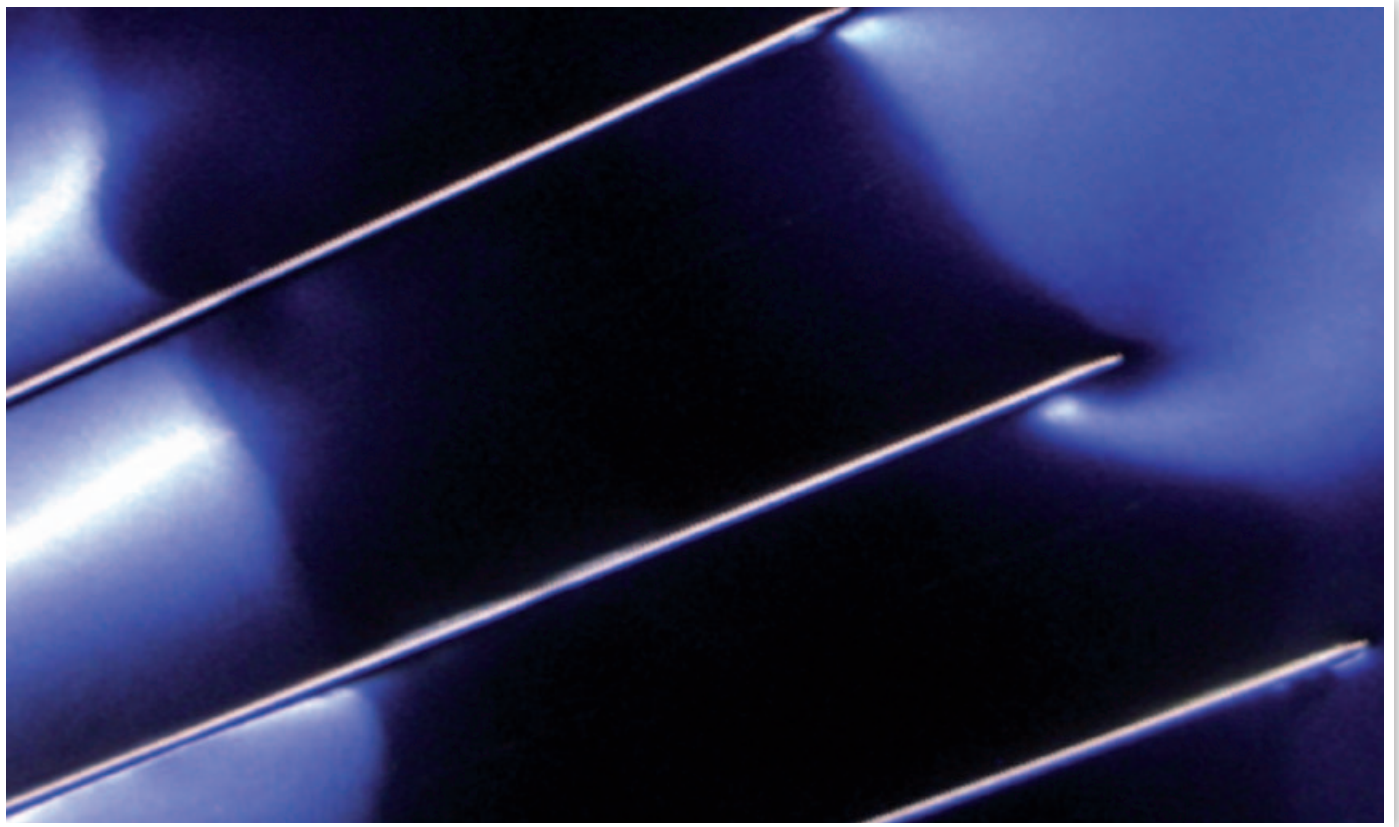

The solar collector is insulated with high-density rock-wool.

The aluminium tray features special ventilation slits to prevent and resolve occasional internal condensate that may occur naturally when there are considerable temperature swings (e.g. night/day).



All research and developments efforts, together with the advanced design and quality control checks let us be extremely confident about the durability of the product, therefore Ferroli can grant 7 years warranty on these solar collectors.



> ACCESSORIES

HAVING A SOLID SUPPORT IS IMPORTANT

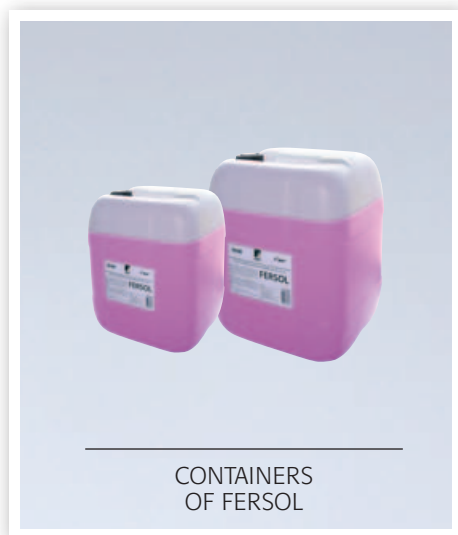

Ferrol supplies a series of dedicated accessories to complete the product:

> FRAMES FOR FLAT ROOFS

Built from painted hot galvanised steel with stainless steel bolts, featuring simplified assembly and easy adjustment.

The frames have passed the strictest approval tests on metallic bars for outdoor uses (e.g. window and door frames), meaning they are also suitable for use in coastal areas and in areas exposed to strong pollution (class 4 as per EN 1670).

> FRAMES FOR SLOPING ROOFS (AND CORRESPONDING BRACKETS FOR TILES: "MARSEILLE" STYLE FLAT TILES, CURVED TILES, SLATE, WOODEN OR SHEET METAL ROOFS)

These are modular and easy to install in unlimited numbers (each collector has a pair of fastening bars that attach to the adjacent one in the group) and are made using the same materials and with the same certification as the frames for flat roofs. They include two fixed brackets for easier collector positioning while

working on the roof.

> NEWS

All the frame systems, both for flat and sloping roofs, are modular (i.e. made up of identical elements), compact in length and easy to store and handle together with the collectors, so as to optimise store space and management for our customers.

That's not all:

> A SPECIAL LINE OF SPECIAL READY-TO-USE (PREMIXED) SOLAR FLUIDS, UNDER THE "FERSOL" BRAND

In 5 kg and 25 kg containers.

The main advantages (in addition to system reliability) are:

- 1) factory premixed with quality controlled demineralised water, to prevent calcification and fouling in all installation and operating conditions of the solar heating system;
- 2) precise and constant composition of the solar fluid, without errors or hassles for mixing on site (for example, when cold glycol is hard to mix with water)
- 3) use of specific inhibitors for high temperatures, which vaporise and condense together with the antifreeze glycol, guaranteeing at all times a controlled range of fluid acidity so as to avoid damaging parts of the system or the collector
- 4) tracing dye that indicates (by changing colour) the need to replace the solar fluid
- 5) use of atoxic and environmentally-friendly propylene glycol as the antifreeze component in the mixture

> TECHNICAL SPECIFICATIONS

SUMMARY TABLE

MODEL		VHM 2.1	VHM 2.7
Dimensions	mm	1037x2018x89	1314x2018x89
Gross area of the collector	m ²	2,09	2,65
Net useful area (absorber)	m ²	1,82	2,36
Total weight	kg	34,4	42,4
Solar circuit fluid content (including storage)	l	0,85	1,09
Stagnation temperature	°C	204,9	204,9
Absorber type	%		95
Absorption factor (absorber)	%		5
Solar collector insulation		40 mm high density mineral wool	
Connections	Ø		3/4"
Max operating pressure solar circuit	bar		10
Connections	nr.		4
Max nr. of collectors in a row	nr.		8
Number of pieces on 1 pallet	nr.	8	8

> TECHNICAL SPECIFICATIONS

TECHNICAL DRAWINGS

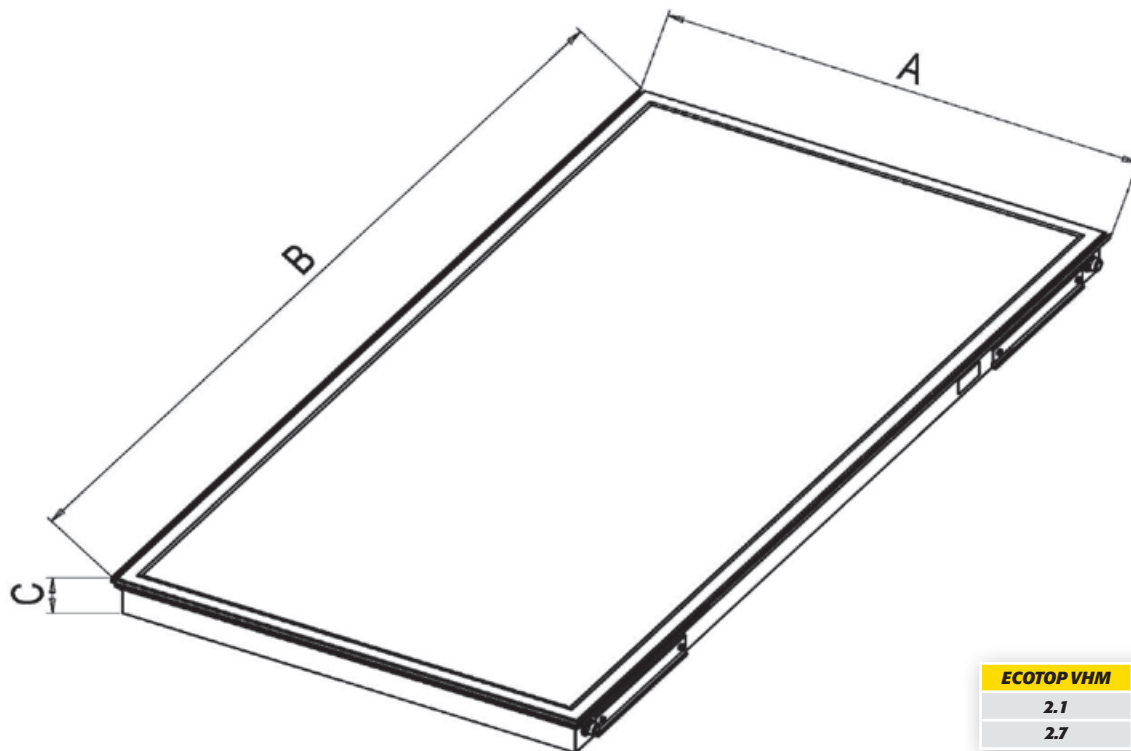

ECOTOP VHM	A (mm)	B (mm)	C (mm)
2.1	1037	2018	89
2.7	1314	2018	89

CERTIFICATE

Certificate holder	Ferrolì S.P.A. Via Ritonda 78 A 37047 San Bonifacio VR ITALY
Production facility	Czechowice-Dziedzice
Product	Solar collectors
Type, Model	VHM 2.1, VHM 2.7
Testing basis	DIN EN 12975-1:2011-01 DIN EN 12975-2:2006-06 Specific CEN Keymark Scheme Rules for Solar Thermal Products Version 28.00 (2015-12)
Mark of conformity	
Registration No.	011-7S2695 F
Valid until	2021-07-31
Right of use	This certificate entitles the holder to use the mark of conformity shown above in conjunction with the specified registration number. See annex for further information.

ANNEX

Page 1 of 1

Certificate	011-7S2695 F dated 2016-09-19
Technical Data	See data sheet, part of the test report of 2013-07-01
	Note(s):
	- The freeze resistance test according to DIN EN 12975-2, clause 5.8 was not necessary. According to the manufacturer's declaration, the certified solar collectors may be used in frost exposed areas only in combination with appropriate frost protection mixtures.
Testing laboratory/ Inspection body	Fundación Cener Ciemat Avda. Ciudad de la Innovación, 7 31621 Sarriguren SPAIN
Test report(s)	30.2047.0-1-1 R, 30.2047.0-2-1 R, 30.2047.0-3-1 R, 30.2047.0 R dated 2013-09-18 30.3022.0 dated 2016-07-05





NOTICE FOR DEALERS:

As part of its efforts to constantly improve its range of products, with the aim of increasing the level of customer satisfaction, the company stresses that the appearance, dimensions, technical data and accessories may be subject to variation.

Consequently, ensure that the customer is provided with up-to-date technical and/or sales documents.

Ferrolì spa

37047 San Bonifacio (VR) Italy - Via Ritonda 78/A

tel. +39.045.6139411

fax +39.045.6100233

www.ferrolì.com

export@ferrolì.it